

parpas

gantry milestone



PRECISIONE VOLUMETRICA • VOLUMETRIC ACCURACY • VOLUMETRISCHE GENAUIGKEIT • PRECISION VOLUMETRIQUE



volumetric accuracy

XS Punto di Riferimento

La XS ha cambiato i termini della precisione, ha introdotto la precisione volumetrica: non solo precisione di posizionamento e ripetibilità, ma precisione del centro e vettore utensile nello spazio ed in tutto il campo operativo della macchina.

XS Referenzpunkt

Die XS Maschine hat den Begriff der Genauigkeit neu definiert: Anstelle der für die 5-Achs-Bearbeitung wenig aussagekräftigen Positionier- und Wiederholgenauigkeit tritt die VOLUMETRISCHE GENAUIGKEIT, die das Zentrum und den Vektor des Werkzeugs im gesamten Arbeitsraum definiert.

XS Point of reference

The XS has modified the accuracy terminology, it has introduced the volumetric accuracy: not only positioning and repeatability accuracy, but accuracy of the tool centre and vector in the space within the full work envelope of the machine.

XS Point de référence

La XS a modifié la terminologie de précision, elle a introduit la précision volumétrique: non seulement les précisions de positionnement et de répétitivité mais aussi la précision du centre et du vecteur de l'outil dans l'espace sur l'enveloppe complète de la machine.

XS background to excellence

Evoluzione della XS

La XS è il risultato di una continua evoluzione e sviluppo tecnologico: a partire dal 1996 (1° versione gantry), sono state eseguite 5 evoluzioni prodotte che hanno coinvolto gli elementi strutturali della macchina, la cinematica e la stabilità termica. Perseguendo l'eccellenza.

4



1996
HSP 14 structural components

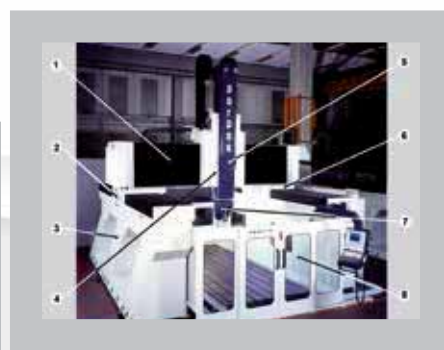

OMNIA 8 structural components



XS 5 structural components



Patent 1
Torque Motors



Patent 2
Thermal Control



Bridge thermal stability

Evolution of the **XS**

XS is the result of a continuous technological development: since 1996 (first gantry version), we have 5 consecutive evolutions of the machine, from the structural elements of the machine to the kinematics and to the thermal stability.

Entwicklung der **XS**

Die XS ist das Ergebnis einer ständigen technologischen Weiterentwicklung: seit 1996 (erste Gantry-Fräsmaschine) haben wir 5 aufeinander aufbauende Generationen der Maschine entwickelt, die jeweils enorme Verbesserungen im Aufbau, der Kinematik und der thermischen Stabilität mit sich gebracht haben. Verfolgung der Exzellenz.

Evolution de la **XS**

La XS est le résultat d'un développement continu et technologique: à partir de 1996 (1ère version de portique), ont été réalisés 5 développements de produits impliquant des éléments structurels de la machine, la cinématique et la stabilité thermique. Dans la poursuite de l'excellence.



Global thermal stability



New design

from virtual to real no limits

Grande campo di lavoro, elevate prestazioni in sgrossatura, alta dinamica in finitura, precisione unica: nessun limite alla realizzazione.

- 6 Große konfigurierbare Arbeitsräume, höchste Dynamik - beeindruckende Steifigkeit, einzigartige Genauigkeit – Der Verwirklichung Ihrer Lösung sind keine Grenzen gesetzt.

Large work envelope, high performance in roughing operations, high dynamic in finishing operations, unique accuracy: no limits.

Grande capacità d'usina, alte performances et ébauche, grande dynamique en finition, précision unique, pas de limites de performance.

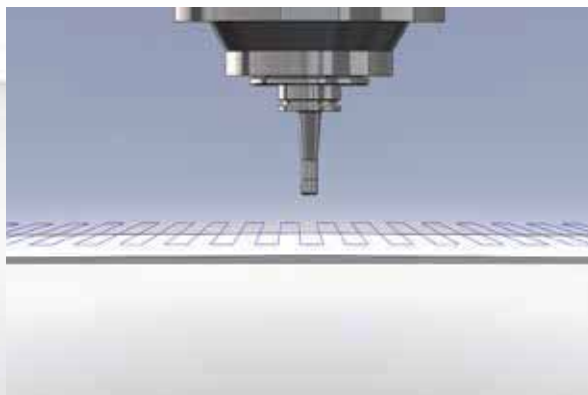



passive thermal management

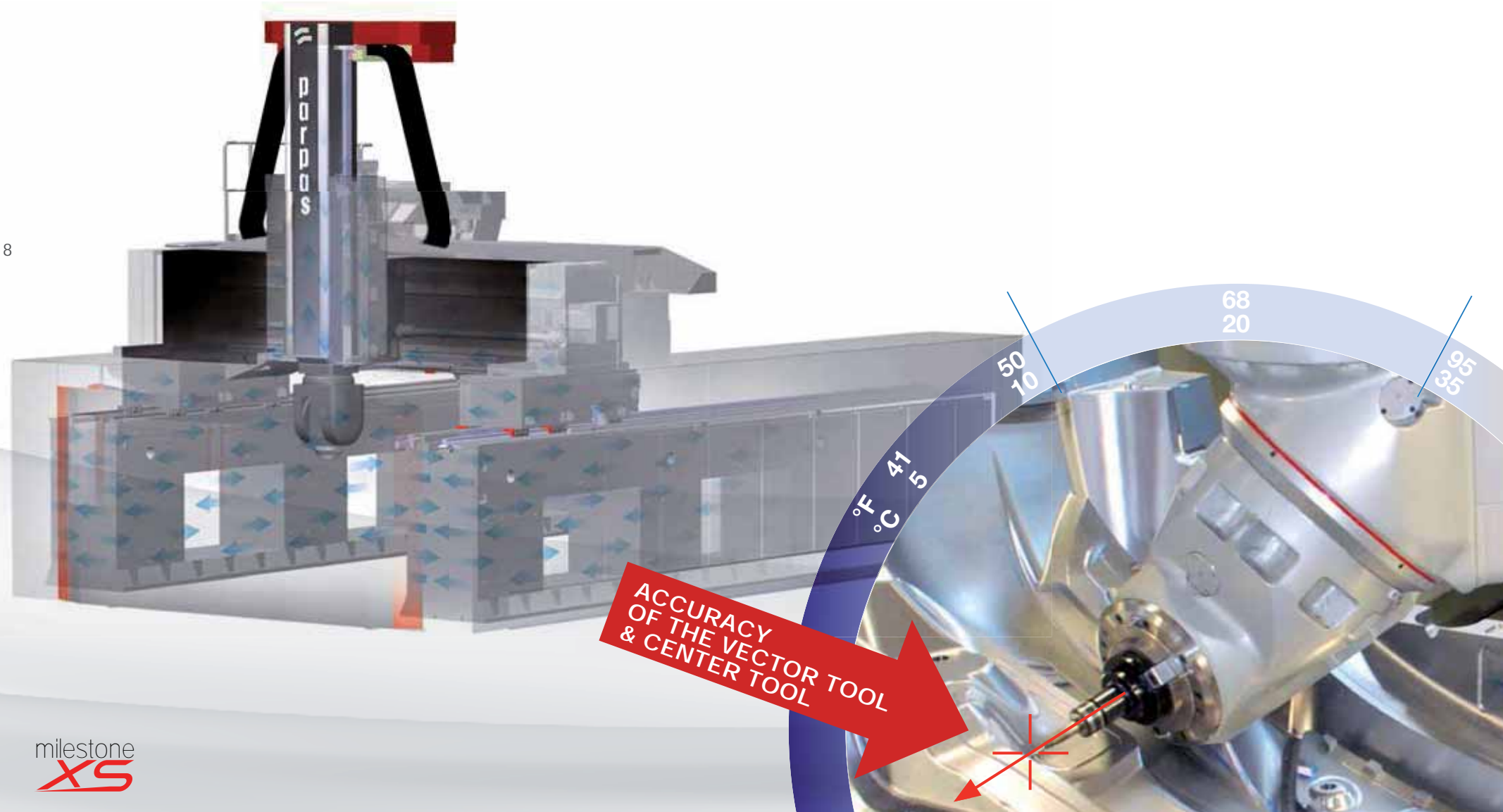

8

generated thermal management

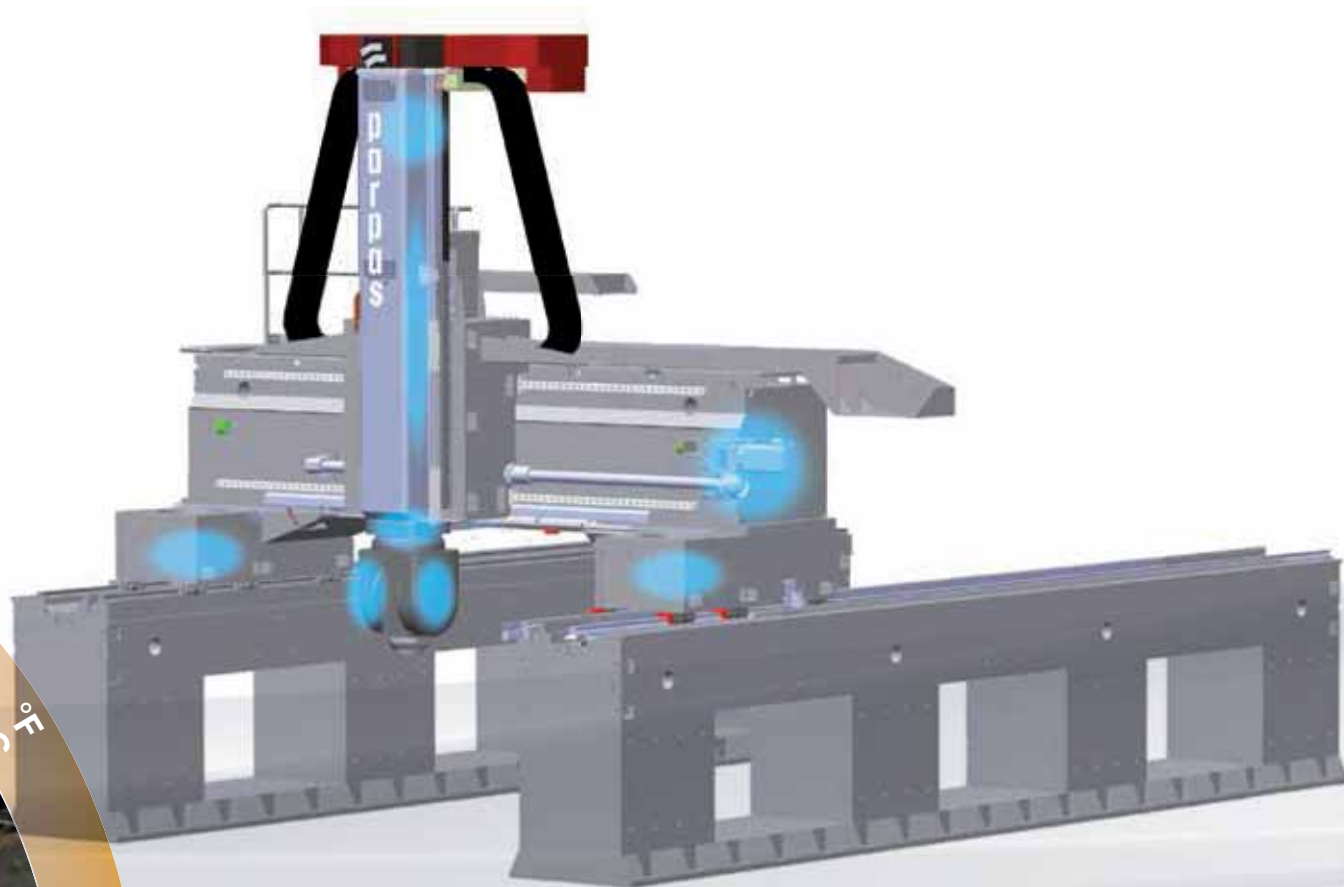

Gestione termica

Grazie a soluzioni tecnologiche brevettate la XS garantisce una continua ed assoluta affidabilità della precisione in ambienti soggetti a variazioni termiche.

Thermal management

Thanks to patented technological solutions, XS delivers a continuous and absolute reliability on accuracy within environments that have temperature variations.

Wärmemanagement

Durch patentierte Lösungen garantiert die XS prozesssicher höchste Genauigkeiten, auch in einem thermisch variablen Umfeld.

Gestion thermique

Grâce à des solutions brevetées, la XS a une fiabilité continue et absolue de précision dans des environnements sujets à des variations de température

patented high dynamic

Dinamica brevettata

Grazie all'innovativa tecnologia TWIN TORQUE MOTORS a trasmissione diretta dell'asse gantry si ottengono grandi coppie di spinta, alta dinamica e velocità fino a 100 m/min (3937 ipm).

Patentierte Dynamik

Dank der innovativen TWIN TORQUE MOTOREN Technologie mit direkter Leistungsübertragung auf die Gantry-Achsen, erreicht die XS hohe Schubleistungen, und eine hohe Dynamik mit Vorschubgeschwindigkeit bis zu 100 m/min (3937 ipm).

Patented dynamic

Thanks to the innovative TWIN TORQUE MOTORS technology with direct transmission on the gantry axis, you will achieve high thrust, high dynamic and feeds up to 100 m/min (3937 ipm).

Dynamique brevetée

Grâce à l'utilisation DE DOUBLE MOTEURS COUPLE avec transmission directe sur les axes du portique, une poussée élevée dynamique et des avances jusqu'à 100 m/min (3937 ipm) peuvent être obtenues.

TTM technology

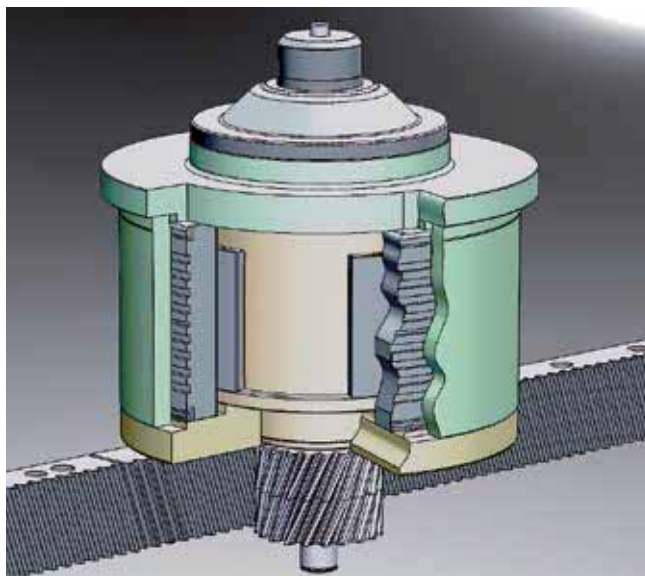

structures-rigidity

Le strutture sono progettate con l'ausilio di potenti sistemi software di calcolo ed analisi. Al fine di ottenere un elevato controllo dinamico della macchina le strutture sono costruite con materiali in lega di acciaio che garantiscono maggior rigidità a parità di massa, rispetto a materiali convenzionali come la ghisa. Le componenti strutturali macchina sono progettate ad elementi in doppia parete scatolati. Tutte le strutture subiscono un trattamento termico distensivo. Grazie al Brevetto che garantisce la costanza termica alle strutture, la traversa gantry è costruita in un solo elemento monoblocco, ottenendo così una elevata rigidità flessor-torsionale. Le guide dello slittone sono in acciaio forgiato e temprato e sono integrali alla struttura, permettono notevoli prestazioni nelle sgrossature più impegnative. Le guide sono nella loro estensione forate ed al loro interno un impianto dedicato fa circolare un liquido a temperatura costante per il mantenimento dell'equilibrio termico tra la struttura dello slittone e le guide stesse.

The structures have been designed using powerful advanced analysis software. With the target to achieve an high dynamic control of the machine, the structures are manufactured with steel alloys ensuring higher rigidity with the same mass compared to conventional materials such as cast iron. The structures of the machines are designed with double wall box concept and they go through thermal stress relief process. Thanks to the Patent giving the thermal stability of the structures, the structure of the gantry is manufactured in a single element which gives an high rigidity to flexion an torsion. The slideways of the ram are in forged hardened steel and integral to the structure of the ram giving very high performances in heavy duty roughing operations. The slideways are also drilled inside with internal cooling liquid circulation to maintain a constant temperature with that of the ram.

Die Strukturen und die Dynamik der Maschine wurden mit Hilfe modernster Analysesoftware entwickelt, mit welcher die statische, dynamische und Vibrations-Steiifigkeit optimiert wurden. Der Grundaufbau erfolgt durch UP-geschweißte Stahlkomponenten, welche gegenüber Guss eine geringere Masse, bei gleicher Steifigkeit ermöglichen. Aufgrund der thermischen Stabilität der Maschine konnte in der Traverse auf eine Dehnfuge verzichtet werden, was die Stabilität erheblich verbessert. Alle Maschinenelement verfügen über einer doppelwandige Struktur mit asymmetrischer Verrippung und werden einer Wärmebehandlung unterzogen um Spannungen zu eliminieren. Die RAM Führungsbahnen bestehen aus gehärtetem Schmiedestahl und sind in der RAM Struktur integriert, was die Biegesteifigkeit der ganzen Baugruppe sehr verstärkt. Die Führungsbahnen sind außerdem mit einer inneren Kühlung ausgestattet, um eine konstante Temperatur des RAM zu erhalten.

Les structures et la dynamique de la machine ont été conçues en utilisant un logiciel d'analyse avancé et sont fabriquées avec des alliages d'acier assurant une plus grande rigidité avec la même masse par rapport aux matériaux conventionnels tels que la fonte. Les structures sont conçues avec des éléments à double paroi et soumises à un traitement thermique de libération des contraintes. Grâce au brevet donnant la stabilité thermique des structures, la structure du portique est fabriquée en un seul élément, ce qui donne une résistance à la flexion et à la torsion élevée même lors de l'usinage de matériaux durs. Les glissières du bélier sont en acier trempé forgé, et font partie intégrante de la structure du bélier améliorant la rigidité globale de l'ensemble. Les glissières sont forées et pourvues d'une circulation de liquide de refroidissement pour maintenir une température constante du bélier.

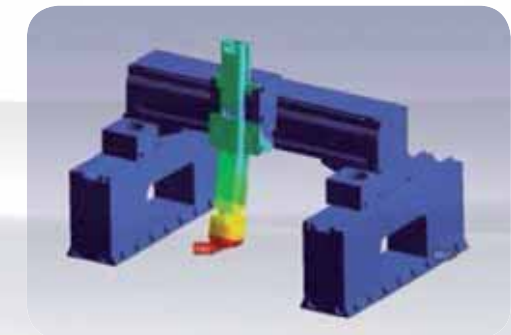
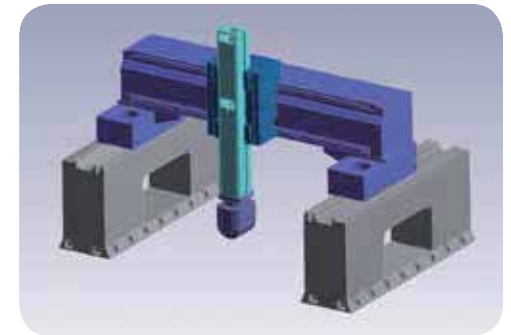

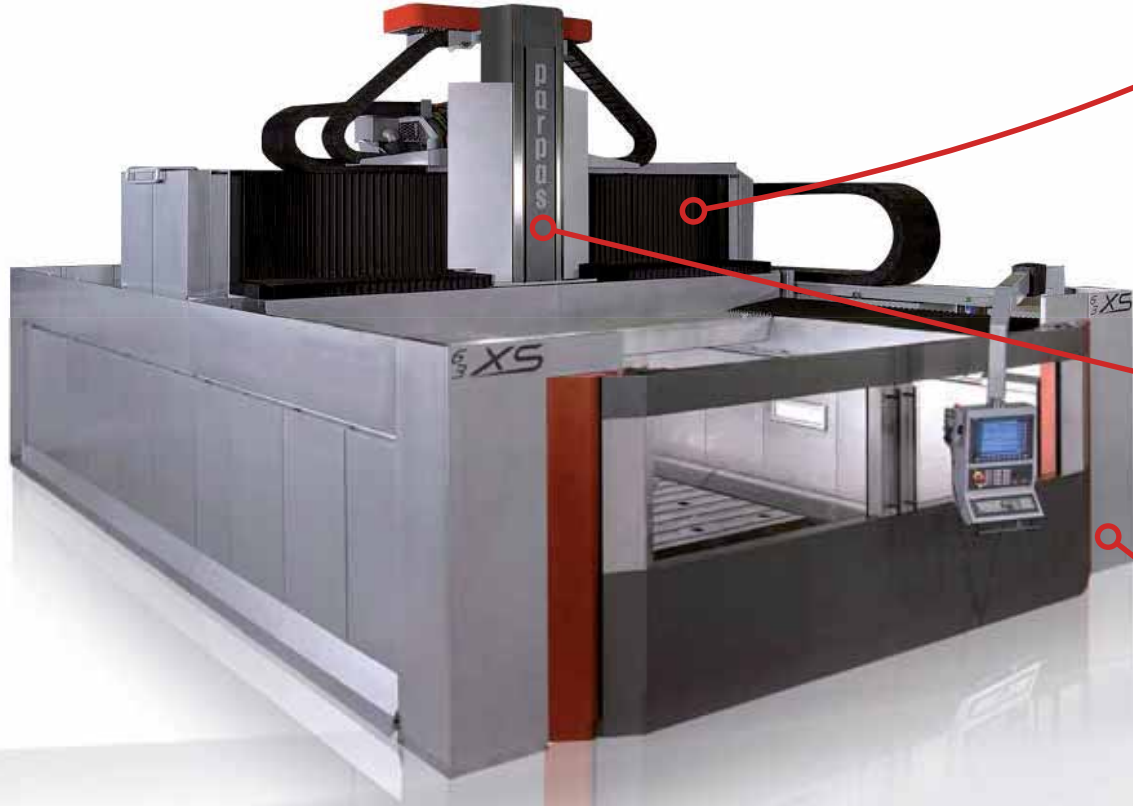

mould & dies

TIC75

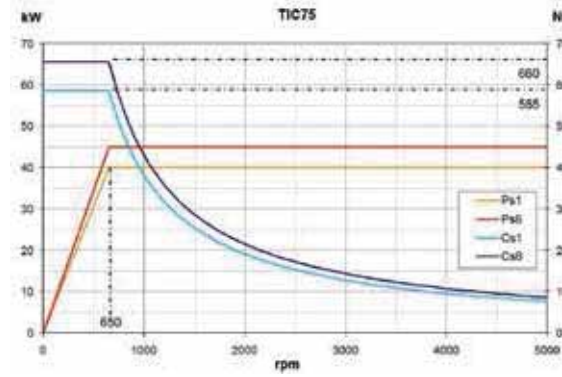

Testa indexata a posizionamento continuo 0,001°
Campo di velocità del mandrino 0-5000 g/1'

Milling head with continuous 0,001 deg. indexing
Spindle speed range 0-5000 rpm

Universalfräskopf aut. schwenkbar, kleinste Teilung 0,001°
Spindeldrehzahlbereich 0-5000 U/min

Tête birotative avec positionnement continu de 0,001°
Vitesse de la broche 0-5000 t/min.

TOE29T

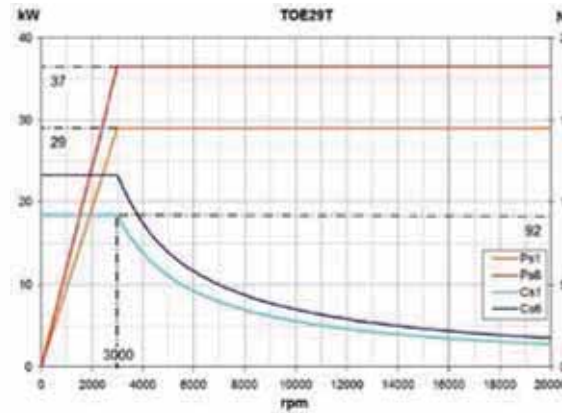

Testa ortogonale indexata direct drive 0,001°
Campo di velocità del mandrino 0-20000 g/1'

Orthogonal milling head with direct drive 0,001 deg. indexing
Spindle speed range 0-20000 rpm

Orthogonal-Fräskopf mit Motorspindel,
kleinste Teilung 0,001°
Spindeldrehzahlbereich 0-20000 U/min

Tête à renvoi, entraînement direct, positionnement continu de 0,001°
Vitesse de la broche 0-20000 t/min.

TPM

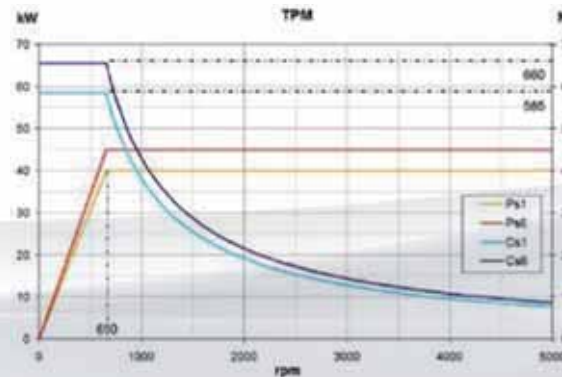

Testa prolunga mandrino
Campo di velocità del mandrino 0-5000 g/1'

Extended spindle head
Spindle speed range 0-5000 rpm

Spindelverlängerung
Spindeldrehzahlbereich 0-5000 U/min

Allonge de broche
Vitesse de la broche 0-5000 t/min.



aerospace

AVIO



Testa a 5 assi azionati da motori coppia (direct drive)
Cambio mandrini automatico

5 axis milling head with torque motors (direct drive)
Automatic spindle change

5 Achsen Gabelfräskopf mit Torque-Antrieben (direct drive)
Aut. Spindelwechsel

Tête à 5 axes continus avec moteurs-couple (entraînement direct)
Changement automatique des broches

16

ELECTROSPINDLE 7000 rpm

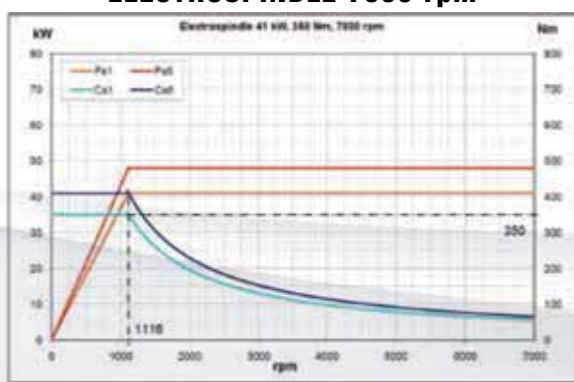

ELECTROSPINDLE 15000 rpm

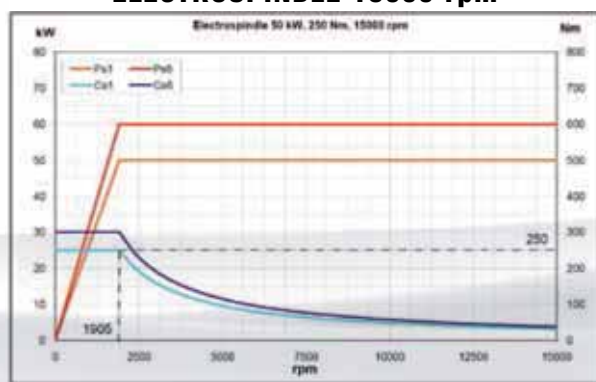

ELECTROSPINDLE 24000 rpm

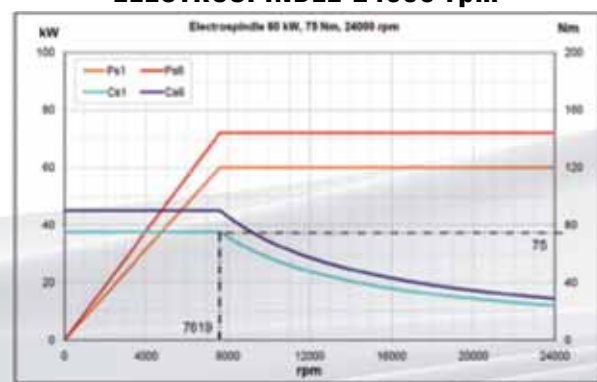

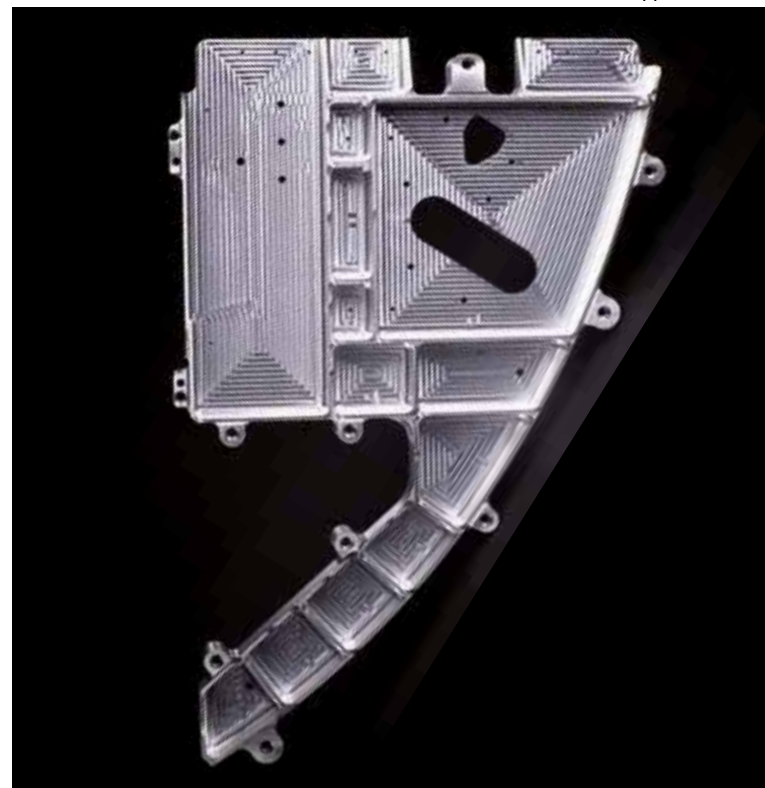

general machining

18

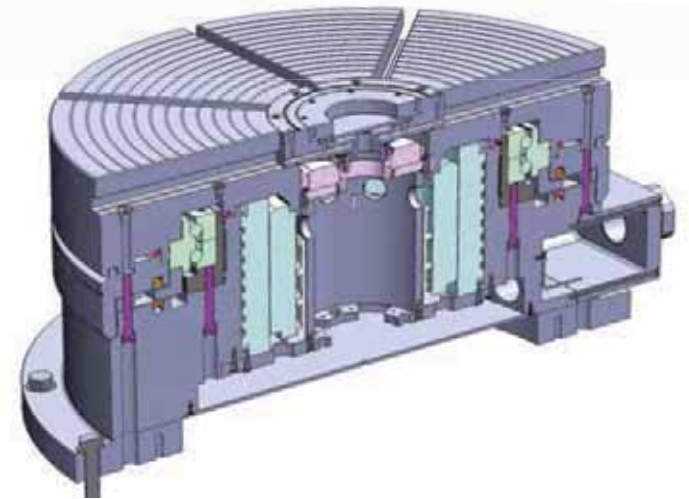

Versatilità

La XS è dotata di cambio teste o mandrini automatico e si configura in funzione delle più svariate esigenze di lavorazione sia di sgrossatura che di superfinitura, su materiali tenaci come acciaio, titanio e inconel o dolci come alluminio, compositi e resine.

Versatility

The XS is equipped with heads or spindles automatic change and can be specifically configured to multiple machining needs both for heavy duty and for finishing, on hard materials such as steel, titanium and inconel or soft such as aluminium, composites and resins.

Vielseitigkeit

Die XS kann mit automatischem Kopf- und/oder Spindel-Wechsler ausgestattet werden, und ist für die verschiedenen Zerspannungsaufgaben konfigurierbar: für das Schruppen und Schlichten, schwer zerspanbarer Materialien wie Stahl, Titan und Inconel, oder weichen wie Aluminium, Verbundwerkstoffen und Harze.

Polyvalence

La XS est équipé avec un changement automatique de têtes ou broches, et conçue pour mener à la fois des travaux d'ébauche et de finition sur des matériaux durs comme l'acier, le titane et l'inconel ou tendres comme l'aluminium, les composites et les résines.

TIC75

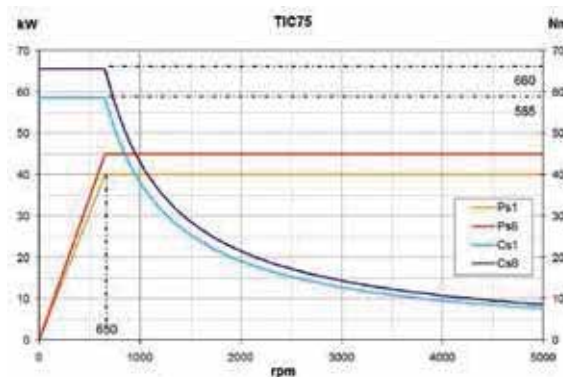

Testa indexata a posizionamento continuo 0,001°
Campo di velocità del mandrino 0-5000 g/1'

Milling head with continuous 0,001 deg. indexing
Spindle speed range 0-5000 rpm

Universalfräskopf aut. Schwenkbar, kleinste Teilung 0,001°
Spindeldrehzahlbereich 0-5000 U/min

Tête birotative avec positionnement continu de 0,001°
Vitesse de la broche 0-5000 t/min.

TWM

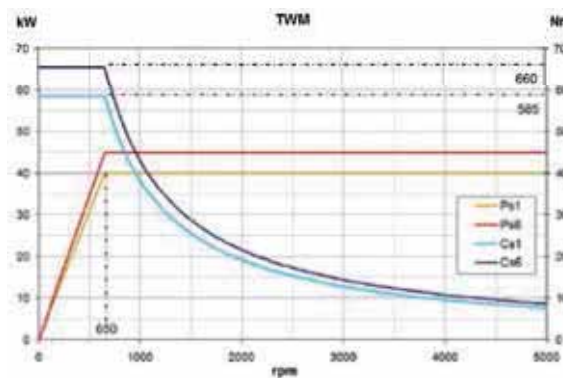

Testa a 5 assi con trasmissione meccanica
Campo di velocità del mandrino 0-6000 g/1'

5 axis geared milling head
Spindle speed range 0-6000 rpm

5 Achsen Gabelfräskopf mit mech. Antrieb
Spindeldrehzahlbereich 0-6000 U/min

Tête à 5 axes continus avec transmission mécanique
Vitesse de la broche 0-6000 t/min.

TPM

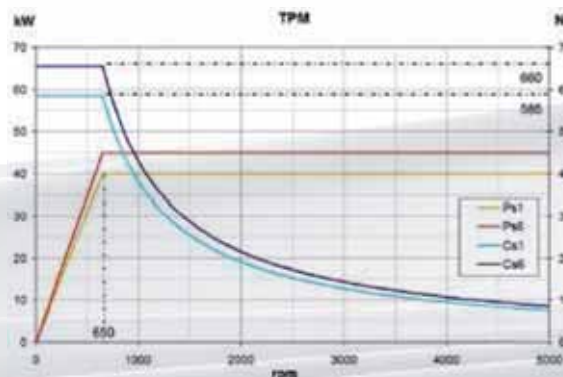

Testa prolunga mandrino
Campo di velocità del mandrino 0-5000 g/1'

Extended spindle head
Spindle speed range 0-5000 rpm

Spindelverlängerung
Spindeldrehzahlbereich 0-5000 U/min

Allonge de broche
Vitesse de la broche 0-5000 t/min.

accessories

Cambio teste automatico
Automatic head change
Aut. Kopfwechsel
Changement têtes automatique



Cambio mandrini automatico
Automatic spindle change
Aut. Spindelwechsel
Changement broches automatique



Videocamera
Camera system
Videokamera
Système vidéo



Copertura
Retractable roof
Dach
Toit rétractable



versions

La XS è stata concepita con modularità strutturali che permettono esecuzioni in varie configurazioni.

The XS has been designed with modular structures allowing versions with multiple configurations.

Der modulare Aufbau der XS bietet verschiedene Ausführungen mit zahlreichen Konfigurationsmöglichkeiten.

La XS a été conçue de manière modulaire, permettant ainsi de très nombreuses configurations.



MULTIAREA

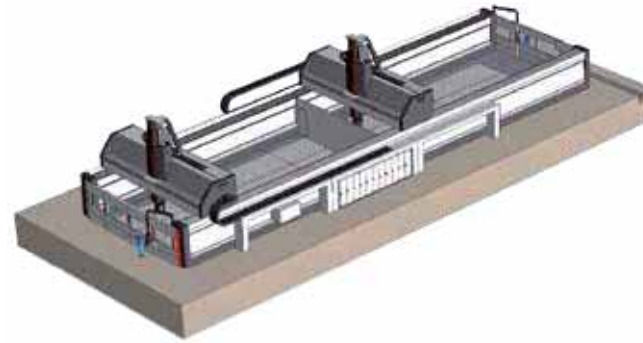

DUPLEX

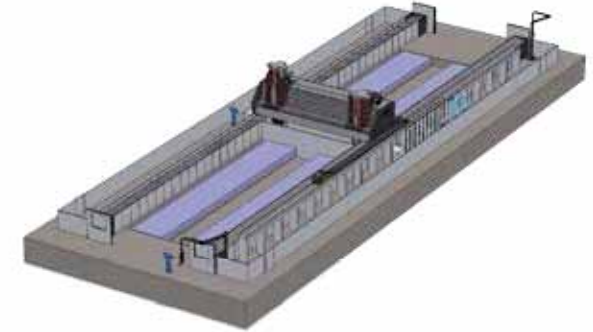

TWIN

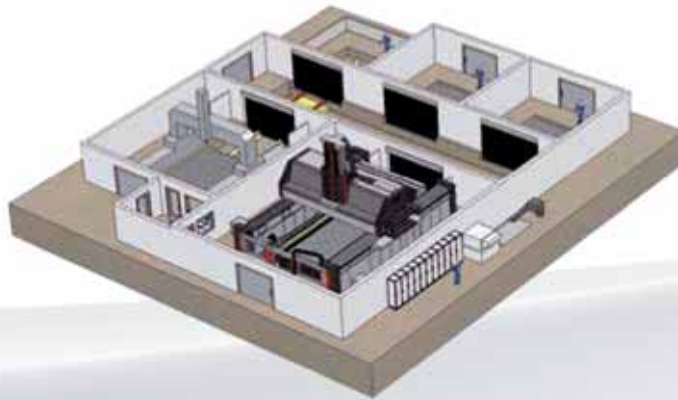

AUTOMATED CELL

GANTRY MACHINE				XS	XS.4
CORSE TRAVELS FAHRWEGE COURSES	Longitudinale - Longitudinal Längs - Longitudinale	X	mm inch	3000 ÷ 20000 118 ÷ 780	6000 ÷ 20000 236 ÷ 780
	Trasversale - Cross Travel Quer - Trasversal	Y	mm inch	2700/3200/3700 106/125/145	4200/4700 165/185
	Verticale - Vertical Senkrecht - Verticale	Z	mm inch	1500/2200 59/86	1500/2200 59/86
AVANZAMENTO FEEDS VORSCHÜBE AVANCES	X (Gantry Twin Torque®)	Brevetto internazionale International patent Internationales Patent Brevet international	mm/1' i.p.m.	0 ÷ 100.000 0 ÷ 3935	
	Y			0 ÷ 40000 0 ÷ 1575	
	Z				
ROTAZIONE ASSE AXIS ROTATION DREHACSE ROTATION AXE	C	Posizionamento continuo Positioning NC-axis Positionier-NC-Achse Positionnement continu	Asse di lavoro Working axis Arbeitsachse Axe de travail	360° / ∞	
CONTINUA STABILITA' TERMICA-GEOMETRICA CONTINUOUS THERMAL-GEOMETRIC STABILITY KONTINUIERLICHE THERMISCH-GEOMETRISCHE STABILITÄT STABILITE THERMIQUE-GEOMETRIQUE CONTINUE		Brevetto internazionale International patent Internationales patent Brevet international			
TAVOLA TABLE TISCH TABLE	Larghezza - Width Breite - Largeur		mm inch	2000 ÷ 4000 78 ÷ 157	
	Lunghezza - Length Länge - Longueur			3000 ÷ 21000 100 ÷ 825	
CAMBIO UTENSILI AUTOMATICO AUTOMATIC TOOL CHANGER AUTOMATISCHER WERKZEUGWECHSLER CHANGEUR AUTOMATIQUE D'OUTILS		Quantità Capacity Ladepazität Capacité	Utensili Tools Werkzeuge Outils	40 ÷ 80 → 250	
CAMBIO TESTE AUTOMATICO AUTOMATIC HEAD CHANGER AUTOMATISCHER KOPFWECHSLER CHANGEUR AUTOMATIQUE DE TÊTES			N°	2 - 3	
CAMBIO ELETTRMANDRINI AUTOMATICO AUTOMATIC ELECTROSPINDLE CHANGER AUTOMATISCHER ELEKTROSPINDELWECHSLER CHANGEMENT ELECTROBROCHE AUTOMATIQUE		TESTA-HEAD-KOPF-TETE T WE-TT	N°	2 - 3	

layout

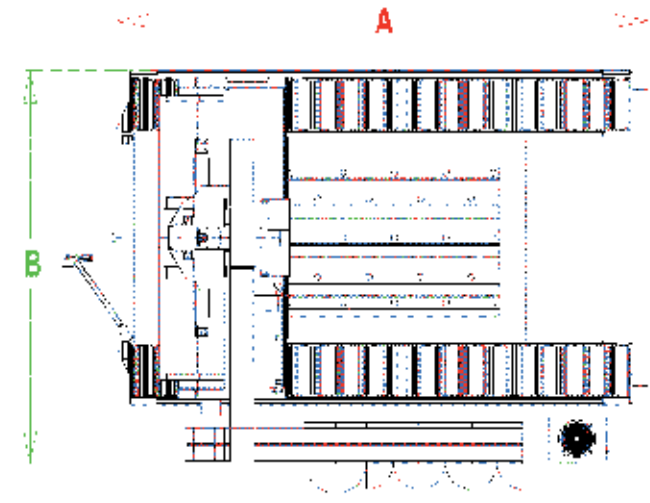
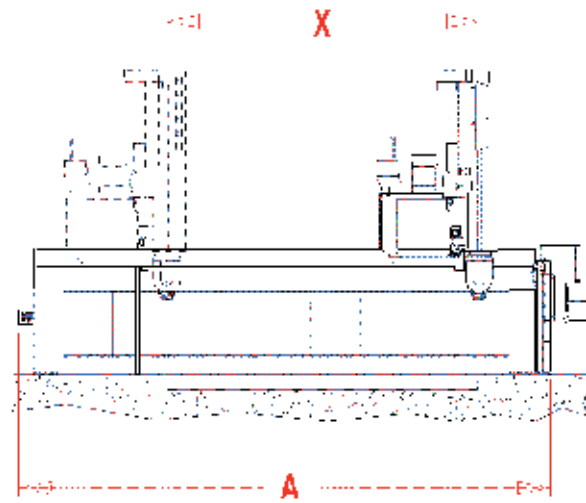
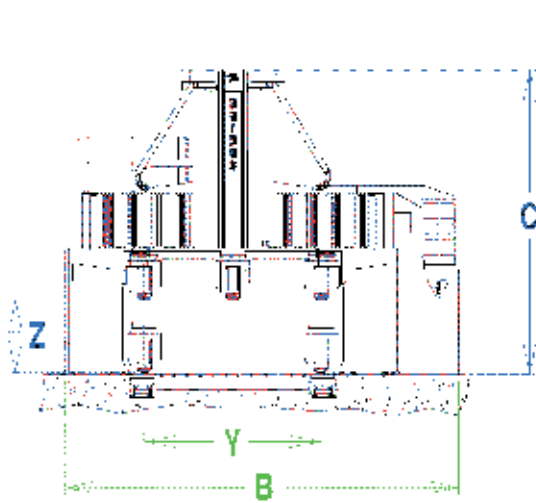

	X mm - in	A mm - in
	4000 - 157	8675 - 342
	6000 - 236	10675 - 421
	>6000 - >236	10675 + 1400/m - 421 + 55/39 in
	Y mm - in	B mm - in
XS	2500 - 98	7000 - 276
	3000 - 118	7500 - 296
	3500 - 138	8000 - 315
XS.4	4000 - 157	8500 - 335
	4500 - 177	9000 - 365
	Z mm - in	C mm - in
	1500 - 59	6000 - 237
	2200 - 86	6900 - 272



parpas

AERO

parpas

parpas

parpas

&...larger

AERO



X	> 6000
Y	5000 ÷ 7600
Z	1500 ÷ 2500

&...others



INVAR		
Corsa Longitudinale Longitudinal Travel Längsverfahrwege Course Longitudinale	mm	6000 + 30000
Corsa Trasversale Cross Travel Querverfahrwege Course Transversale	mm	1250 + 1000 1500 + 1250
Corsa Verticale Vertical Travel Senkrechtsverfahrwege Course Verticale	mm	3000 + 8000
Avanzamenti Feeds Vorschübe Avances	mm/T	0 ÷ 25000
Motore mandrino Spindle motor Spindelmotor Moteur de broche	Kw Nm	80 • 100 7600 • 14500



ML-120		
Corsa Longitudinale Longitudinal Travel Längsverfahrwege Course Longitudinale	mm	4000 + 30000
Corsa Trasversale Cross Travel Querverfahrwege Course Transversale	mm	1250 • 1500
Corsa Verticale Vertical Travel Senkrechtsverfahrwege Course Verticale	mm	2500 + 4500
Avanzamenti Feeds Vorschübe Avances	mm/T	0 ÷ 25000
Motore mandrino Spindle motor Spindelmotor Moteur de broche	Kw Nm	46 1740



ML-200		
Corsa Longitudinale Longitudinal Travel Längsverfahrwege Course Longitudinale	mm	6000 + 30000
Corsa Trasversale Cross Travel Querverfahrwege Course Transversale	mm	1500
Corsa Verticale Vertical Travel Senkrechtsverfahrwege Course Verticale	mm	2500 + 4500
Avanzamenti Feeds Vorschübe Avances	mm/T	0 ÷ 25000
Motore mandrino Spindle motor Spindelmotor Moteur de broche	Kw Nm	46 • 55 1740 - 5400

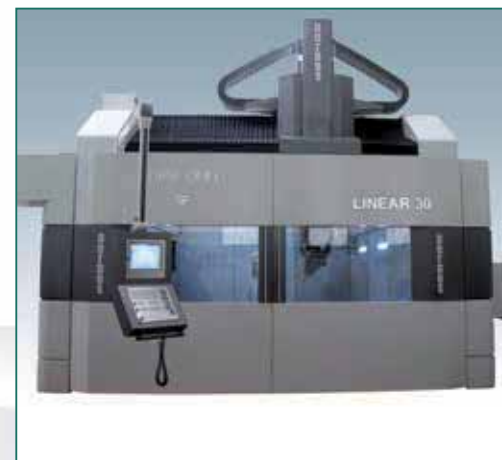

DIAMOND linear 30		
Corsa Longitudinale Longitudinal Travel Längsverfahrwege Course Longitudinale	mm	3000
Corsa Trasversale Cross Travel Querverfahrwege Course Transversale	mm	2600
Corsa Verticale Vertical Travel Senkrechtsverfahrwege Course Verticale	mm	1200 + 1400
Avanzamenti Feeds Vorschübe Avances	mm/T	1200 ÷ 1400
Motore mandrino Spindle motor Spindelmotor Moteur de broche	Kw rpm	29 ÷ 41 15000 + 20000



DIAMOND		
Corsa Longitudinale Longitudinal Travel Längsverfahrwege Course Longitudinale	mm	2200 (+220)
Corsa Trasversale Cross Travel Querverfahrwege Course Transversale	mm	1500 (+220)
Corsa Verticale Vertical Travel Senkrechtverfahrwege Course Verticale	mm	1000
Avanzamenti Feeds Vorschübe Avances	mm/1'	0 ÷ 40000
Testa 5 assi motomandrino 5 axes head motorspindle 5 Achsen-kopf motorspindel Tête à 5 axes electrobroche	Kw	29
	rpm	22000



THS 100		
Corsa Longitudinale Longitudinal Travel Längsverfahrwege Course Longitudinale	mm	1500 • 2000 • 2500
Corsa Trasversale Cross Travel Querverfahrwege Course Transversale	mm	1000
Corsa Verticale Vertical Travel Senkrechtverfahrwege Course Verticale	mm	1200
Avanzamenti Feeds Vorschübe Avances	mm/1'	0 ÷ 40000
Motore mandrino Spindle motor Spindelmotor Moteur de broche	Kw	29 + 64
	rpm	7000 ÷ 20000



THS - TILT		
Corsa Longitudinale Longitudinal Travel Längsverfahrwege Course Longitudinale	mm	1600 ÷ 3000
Corsa Trasversale Cross Travel Querverfahrwege Course Transversale	mm	1250 ÷ 2000
Corsa Verticale Vertical Travel Senkrechtverfahrwege Course Verticale	mm	1250 ÷ 2400
Avanzamenti Feeds Vorschübe Avances	mm/1'	0 ÷ 30000
Motore mandrino Spindle motor Spindelmotor Moteur de broche	Kw	30 + 65
	rpm	5000 ÷ 20000

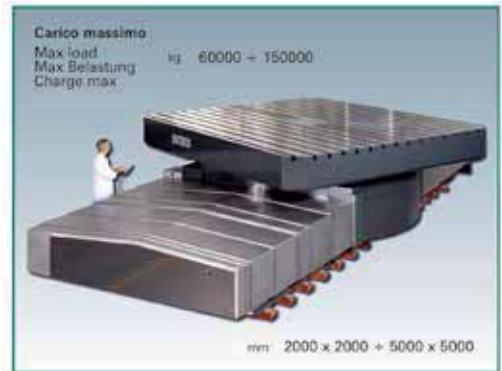



www.gruppoparpas.com



PARPAS SpA
Via Firenze, 21
35010 Cadoneghe (PD)
Tel : +39 049 700711
Fax : +39 049 703292
email : info@parpas.com



PARPAS DEUTSCHLAND GmbH
Markusstraße 9
D-96047 Bamberg
Tel : +49 951 30943483
Fax : +49 951 30943487
email : team@parpas.de



PARPAS AMERICA CORPORATION
791 Industrial Court
Bloomfield Hills, MI 48302, USA
Tel : +1 248-253-6000
Fax : +1 248-253-6001
email : info@parpasamerica.com



PARPAS AMERICA INC.
5425 Outer Drive
Windsor, Ontario N9A 6J3, Canada
Tel : +1 248-253-6000
Fax : +1 248-253-6001
email : info@parpasamerica.com